



MODIFIED

2026 TECHNICAL RULEBOOK

ENGINE RULES

PENTON ENGINE RULES IN GENERAL RULES ALSO APPLY

Engine Option #1

1. Chevrolet Performance Part #88958602/19258602/88858602 (CT350) commonly referred to as "602" engine.
2. These engines are sealed at the intake manifold, cylinder head, front cover, and oil pan with special Chevrolet Performance cap seals, which are installed at the Chevrolet Performance factory.
3. The ONLY seals allowed for competition are:
 - a. GM twist off bolt engines will NOT be legal.
 - b. Chevrolet Performance cap seals
 - c. Crate USA Gen IV (Green) or Gen V (Black) cable seals, RUSH cable seals, IMCA cable seals allowed.
 - d. NO ACAS, NDRA, FASTRAK, Crate USA Gen I (Silver), Gen II (Blue), Gen III (Yellow) will be allowed.
 - e. To compete with ANY other seal/sealing system contact Penton Raceway Technical Inspector for approval.
4. These sealed engines must not be altered, modified, or changed from factory specs. The sealed engines must remain intact and not tampered with.
 - a. Approved changes/modifications for Chevrolet Performance 602 engines are noted as follows:
 - i. Engine rings may be replaced with the Hastings Ring (Part #2M4860) ii. Engine may run King (Part #MB5575I), Speed Pro (Part #139M) or Clevite "P" (Part #M5909P) Main Bearings. King (Part#CR8075I), Speed Pro (Part#8-7100CH), or Clevite "P" (Part #CB663P) Rod Bearings. No narrowed bearings.
5. No changes are allowed to the engine including the intake manifold, heads, valve covers, front cover, oil pan, harmonic balancer, or any other part(s) on or in the engine, unless noted otherwise or approved by Crate Racin' USA officials.
6. No vacuum pumps. No evac systems of any type, including but not limited to the breather

system style.

7. Engine's Chevrolet Performance serial number, and when applicable, Crate USA build certification number, must be clearly visible to track technical inspectors.

Engine Option #2

1. 362 cubic inch maximum, factory steel production blocks.
2. Any cast iron 23* steel heads. No porting or polishing of cylinder head. No aluminum heads.
3. Max valve size: 2.02" intake, and 1.6" exhaust.
4. Any intake manifolds. No porting or polishing.
5. Steel or cast cranks and rods. No exotic material cranks or rods (ex.: aluminum or titanium)
6. Flat top pistons only.
7. Any flat tappet camshaft only. No roller cams.
8. Timing chains only. No gear drives.
9. Stud mount rockers only. No stud girdles.
10. Stock diameter valve springs only. 1.260" maximum O.D. Beehive springs allowed, 1.320" maximum O.D., ANY manufacturer (Chevy, Ford, or Dodge). NO double valve springs.

WEIGHT

1. Cars equipped with Chevrolet Performance 602 (Engine Option #1) must weigh 2,400 lbs.
2. Cars equipped with engines falling under Engine Option #2 Rules must weigh 2,600 lbs.
3. All cars will be allowed 1 lb. per green flag lap burnoff allowance at the completion of any race
4. ALL weight/lead must be painted white and include the car number. Weight must be securely fastened to the car with a minimum two (2) ½" diameter bolts. No weight may be attached to the back bumper. Losing weight in any race (i.e. heat, b-main, feature) will result in disqualification for that event.

ENGINE SETBACK RULE

1. Engine bell housing flange to center of axle tube- 70" minimum.

CARBURETOR

1. Engine Option #2- 500 CFM 2 barrel only.
2. 2 Barrel carburetors will be checked with go-no-go gauges top to bottom.
3. Either engine Option may run 1" maximum carburetor spacer, .040" tolerance. At no point may spacer extend into intake manifold area. Two (2) standard thickness carburetor gaskets, .070" maximum thickness allowed.
4. Engine Option #1- may run one (1) four-barrel carburetor only.
5. All carburetors (for both engine options) must have conventional style floats along with needles and seats. NO individual cylinder tuning or equivalent allowed.
6. All carburetors (for both engine options) must have conventional "Holley-style" straight or down leg boosters. NO exceptions. NO super bowl type carburetors allowed. Willy's Equalizer Carburetor OK for competition.

DISTRIBUTOR

1. No magnetos.
2. MSD is ok- 6AL or 6ALN MSD box ONLY.
3. Track reserves the right to change MSD boxes with any car at any time.

STARTER

1. All cars must have a starter in working order. Starter must be mounted in stock location.

WATER PUMP AND POWER STEERING PUMP

1. Stock skypc cast or aluminum water pump permitted.
2. No electric water pumps.
3. Manual fans only. No electric fans.

EXHAUST RULES - MUFFLERS REQUIRED AT PENTON RACEWAY

1. Collector type headers required. Must have four (4) tube into one (1) collector.
2. Any commercially manufactured muffler - MUST register under 100 decibels.
3. No tri-y headers or merged headers allowed.
4. No square tube headers.

ROLL CAGE

1. Must be constructed of minimum 1.50" O.D. steel tubing, with a minimum wall thickness of .095".
2. Minimum of 3 door bars, minimum of 1.50" O.D. steel tubing and .083" minimum wall thickness on driver's side.
3. Minimum of 2 door bars on passenger side.
4. Driver's head/helmet should not protrude outside of cage with helmet on.

BODY

1. See 2024 Body diagram/Specifications for specific body measurements.
2. Full size fiberglass or aluminum roofs. No dished roofs.
3. Cars may NOT run topless.
4. Sail panels- must be solid and meet specifications in attached diagram. Must be mounted within 2" of outside edge or interior deck.
5. Rear spoiler - 4" maximum material height and maximum 67" wide. Maximum three (3) spoiler braces allowed, must be mounted in line, equal material. No wings, lips, or fins of any type allowed.
6. Aluminum nose panel must be flat, with a maximum 2" side fins allowed on nose.
7. Engine compartment must remain open, with no side panels.
8. Nose pieces may be maximum 42" width, centered between frame rails, and must not extend past the leading edge of the front bumper.
9. No rub rails, or any bars of any type outside of the tires/body panels allowed.
10. Maximum width at back of quarter panels (measured at the bottom) 72" maximum- Body Diagram T
11. Maximum width at the bottom of doors (measured in front of rear tire) 72" maximum- Body Diagram U.

TRANSMISSION AND DRIVELINE

1. No straight/direct drives. No in or out boxes.
2. Bert, Brinn, or equivalent ok. Aluminum bell housing OK and recommended.
3. Drive shaft loop mandatory on all cars. Must be mounted 5" to 8" behind front U-joint of drive shaft.
4. All drive shafts must be painted white for safety, if not carbon fiber or aluminum.

SUSPENSION

No data acquisition devices of any type allowed.

FRONT SUSPENSION

1. No spring rubbers.
2. Any stamped steel, stock, unaltered lower control arm. When utilizing tubular lower control arms, one side must be OEM measurements. The opposite side may be +/- 1" of OEM measurements.
3. One spring rubber allowed per corner. No progressive springs.
4. Stock lower control arms must be mounted in stock location. May also use track approved WMP Products Part #1010 (Metric/Monte Carlo right side); #1011 (Metric/Monte Carlo left side); and #1210 (Camaro/Chevelle right side) and #1211 (Camaro/Chevelle left side).
5. Any stock passenger car spindles.
6. One spring allowed on each corner. Must be a minimum of 5".
7. Tubular upper A-frames allowed. Upper A-frame mounts may be relocated.
8. Lower A-frame mounts cannot be altered. Must remain stock and in stock location.
9. No bump stops of any type allowed.
10. No chains/limiters of any type allowed.
11. Stock type steering box. No rack and pinion. Steering quickener ok. Stock center link.
12. Tie rods may be tubular and made with heim joints.
13. Steel brake rotors and calipers only. No aluminum suspension parts allowed.

REAR SUSPENSION

1. One spring rubber allowed per corner. No progressive springs.
2. Quick change rear ends allowed. Magnetic steel axle tubes, hubs, rotors, and drive flanges only. No gun drilled axles.
3. Steel brake rotors and calipers only. NO brake floaters.
4. All rear suspension mounts and/or brackets must be welded or bolted solid.
5. One spring allowed on each corner. All springs must be a minimum of 5".
6. All rear springs must be mounted centerline of rear end housing.
7. No sliders
8. Three (3) link suspension setups must adhere to the following requirements:
 - a. Lower control arms must be a maximum length of 24" and minimum of 15".
 - b. Upper control arm should be constructed of solid material with no bushings or springs located at the top center of the rear end housing and remain centered over the rear end housing and top of the drive shaft (1" tolerance). No movable brackets.
 - c. One panhard bar, minimum 23" length, may be mounted behind the rear end housing.
 - d. J-bar may be used, minimum 19 1/2" length. Must be mounted from left side of chassis to the right side of the drive shaft.
 - e. Rear springs must be mounted on top of axle tube. Center of spring must be center of axle tube. Zero tolerance!
9. No gun drilled axles
10. Stock OEM suspension setups must adhere to the following requirements:
 - a. Lower control arms must remain in stock location on chassis.
 - b. Lower control arms must be mounted no lower than 2 3/4" from bottom of axle tube.
 - c. Upper control arms must remain in stock location on chassis.
 - d. Upper control arm mounts 7 3/4" from center of axle tube to center of mounting bolts.
 - e. Rear springs must be mounted on top of axle tube. Center of spring must be center of axle tube. Zero tolerance!

SUSPENSION

PENTON SUSPENSION RULES IN GENERAL RULES ALSO APPLY

1. Leaf spring suspension- any leaf spring allowed. No coil springs allowed.
2. No bump stops of any type allowed.
3. Solid limiting chain allowed on left and right rear suspension only. Must be a solid chain.
4. J-bar mount at frame and pinion may be aluminum. No other aluminum suspension parts allowed.

CHASSIS AND FRAME

1. Wheelbase- minimum 108", maximum 112". 1" tolerance maximum.
2. Stock production frames only. Must extend from 1" in front of power steering box to mid-plate.

FUEL, FUEL CELL, AND FUEL PUMP

1. An approved fuel cell must be securely mounted in the trunk area of the car, inside a .20 gauge metal box supported by a minimum of 2" x 1/8" steel straps.
2. Gasoline, Racing Gas, or E-85 fuel allowed. No methanol or alcohol. None of the following chemicals are allowed in any fuel used for competition: No nitrous oxide, propylene oxide, nitroethane, MTBE, hydrazine, or ethylhexanol.
 - a. Gasoline or Race Gas: specific gravity NOT to exceed .744 at 60 degrees. Any gasoline or race gas with a specific gravity of .745 or greater will be disqualified. Fuel is subject to testing on site, or fuel samples may be taken and sent to an independent lab for testing.
 - b. E-85: specific gravity not to exceed .7855 at 60 degrees. Any E-85 with a specific gravity of .7856 or greater will be disqualified. Fuel is subject to testing on site, or fuel samples may be taken and sent to an independent lab for testing.
 - c. It is the competitor's responsibility to know what is being put into their fuel cell.
3. Mechanical fuel pump only. Must be mounted in stock location.

SHOCKS

1. Steel bodied, symmetric (same size/diameter), non-adjustable shocks only. Shocks must have solid shafts. No Shrader valve shocks. No piercing valves. Shock valving or gas pressure may not be adjustable at the racetrack. No shock covers. No air shocks. No remote reservoir shocks.
2. Shocks must fully collapse. No internal bumps allowed.
3. One shock per corner.

TIRES AND WHEELS

1. 8" maximum steel wheels. Beadlocks allowed. Stock type lug pattern only.
2. No wide 5 wheels or adapters.
3. Wheel covers must be securely fastened. Recommend that wheel covers have a minimum of 5 mounting points. Wheel covers having only 3 attachment points must be bolted on at all 3 points using a minimum 1/4" or 5/16" magnetic steel hex head bolt and fastening (nut assembly) system. Cars that lose a wheel cover may be subject to disqualification.
4. Hoosier H500 tires. American Racer Stocker Hard and AR 500 allowed.
5. Grooving or siping are allowed. Grinding/buffing is permitted. NO drilling.
6. Tires must remain in factory manufactured condition. Any alteration from factory manufactured condition. Any alteration from factory manufactured condition is prohibited. All decisions are final.
7. No chemically altering of tires.

8. Tires must punch 55 at ambient temperature (cold). The track durometer is the official durometer and testing method of punch number rule.

SAFETY

PENTON SAFETY RULES IN GENERAL RULES ALSO APPLY

1. Approved helmet and full fire resistant driver's suit required.
2. All cars must have 3" lap belt and 2" shoulder harness and crotch strap MINIMUM and must be attached to the roll cage.
3. All cars must have an approved fire extinguisher, securely mounted, within easy reach of the driver. A 10 lb. halon system is recommended.

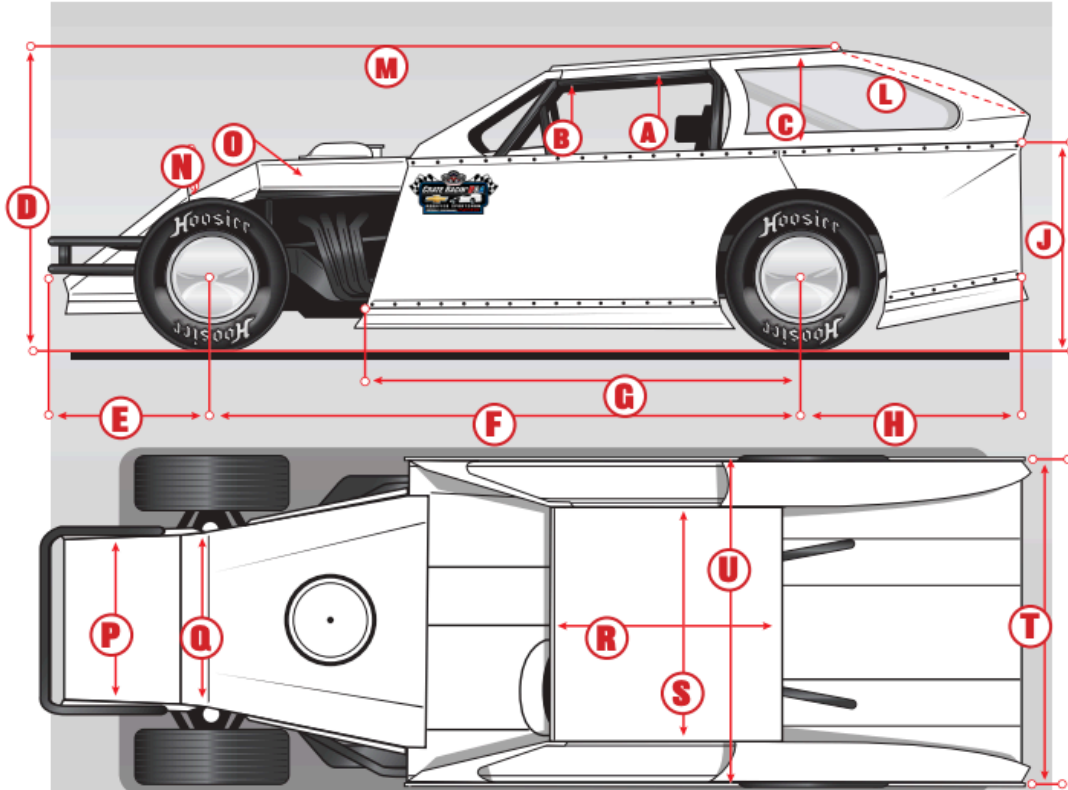

2026 MODIFIED DIMENSIONS

- A)** Window opening-12" min-18" max.
- B)** Front edge of roof to interior deck-11" min.
- C)** Rear edge of roof to interior deck-12" min.
- D)** Highest point of roof to ground-42" min-52" max.
- E)** Center of front wheel to front edge of front bumper-42".
- F)** Wheelbase: center of rear wheel to center of front wheel-108" min-112" max.
- G)** Center of rear wheel to front edge of door-72" max.
- H)** Center of rear wheel to rear edge of quarter panel-34" min-47" max.
- I)** Center of lowest bar on rear bumper to ground-16-20" max.
- J)** Deck height to ground-28" min-38" max.
- K)** Rear sail panel height 4" max.
- L)** Sail panel curve from rear of roof to rear of panel-2" max.
- M)** Sail panel bow from bottom to roof-2" max.
- N)** 2" max lip, same on both sides flush with hood.
- O)** 5" max drop (sides) sealed off from driver's compartment and max 6" rake.
- P)** 42" max nose must be flat and flush with sides.
- Q)** 67" max 42" min, must cover radiator
- R)** 53" max 32" min
- S)** 53" max 32" min
- T)** 67" max 55" mini, measured at top of interior deck, must be same from back to front. Back of quarter panels 72" Max (measured at the bottom, plus six inches max on the left side door for tire clearance) 78" total
- U)** Width at the bottom of the doors (measured in front of rear tires) 72" Max

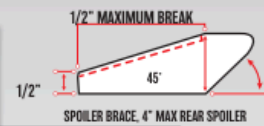

SPOILER BRACE, 4" MAX REAR SPOILER

